

White-Rodgers™

TYPE 1A10-1A16 SERIES

Light Duty Line Voltage Heating-Cooling

INSTALLATION INSTRUCTIONS

Operator: Save these instructions for future use!

FAILURE TO READ AND FOLLOW ALL INSTRUCTIONS CAREFULLY BEFORE INSTALLING OR OPERATING THIS CONTROL COULD CAUSE PERSONAL INJURY AND/OR PROPERTY DAMAGE.

DESCRIPTION

This Light Duty Line Voltage Heating-Cooling Thermostat is designed for controlling fan motors, circulator motors, contactors, motor starters, valves, etc. To provide greater room comfort, the thermostat is equipped with fixed anticipators.

Two dial stops are supplied, which may be used for making a maximum or minimum setting, a limited temperature range or a locked dial setting. (See parts package).

The temperature may be set anywhere between 36° and 90°F or 2° and 32°C by turning knob to the desired temperature on the dial.

Positive off or system selection can be obtained by using a switching sub-base. Optional heating and cooling sub-base S29-21 is available.

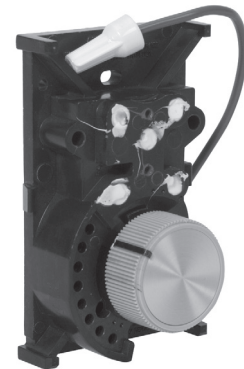

SPECIFICATIONS

Switch Action: S.P. D.T.

(Heating, open on rise)

(Cooling, close on rise)

Range: 36 to 90°F (2° to 32°C)

Contact Structure: Snap Switch

⚠ CAUTION

When thermostat is set below 40°F or 5°C, damage to the building and/or contents may result due to freezing. This is possible due to factory calibration tolerances, thermostat location and operating characteristics of the heating equipment.

Electrical Rating:

Model Number	Range	Differential	Switch Action	A.C. Electrical Ratings						Pilot Duty
				Heat				Cool		
				Voltage	Full Load	Locked Rotor	Resistive (Non-Inductive)	Full Load	Locked Rotor	
1A10-651	36 to 90°F (2 to 32°C)	1.5°F	SPDT	120	8.0A	48.0A	8.0A	8.0A	48.0A	125 VA 125 VA
				240 / 277	4.0A	24.0A	8.0A	4.0A	24.0A	
1A16-51	36 to 90°F (2 to 32°C)	1.5°F	SPDT	120	16.0A	96.0A	16.0A	8.0A	48.0A	125 VA 125 VA
				240 / 277	8.0A	48.0A	16.0A	4.0A	24.0A	

SELECTING LOCATION

The proper location of the room thermostat is most important to insure that it will provide a comfortable home temperature. Observe the following general rules when selecting a location:

1. Locate it about 5 ft. above the floor.
2. Install it on a partitioning wall, not on an outside wall.
3. Never expose it to direct light from lamps, sun, fireplaces or any temperature radiating equipment.
4. Avoid locations close to doors that lead outside, windows, or adjoining outside walls.
5. Avoid locations close to air registers, or in the direct path of air from them.
6. Make sure there are no pipes or duct work in that part of the wall chosen for the thermostat location.
7. Never locate it in a room that is warmer or cooler than the rest of the home, such as the kitchen.
8. Avoid location with lack of air circulation, such as behind doors or alcoves.
9. The living or dining room is normally a good location, provided there is no cooking range or refrigerator on opposite side of wall.

INSTALLATION

⚠ CAUTION

To prevent electrical shock and/or equipment damage, disconnect electric power to system, at main fuse or circuit breaker box, until installation is complete.

The thermostat may be mounted in any standard 3"x 2" or 4"x 2" electrical outlet box. For ease of installation, use a deep type box. **USE COPPER CONDUCTORS ONLY.**

Installation should be made as follows:

1. Cut field just long enough to reach wiring terminals with thermostat held in palm of hand. (Appx. 6")
2. Strip field wires 1/2" and make connections to wiring terminals. Connect load (or loads) as shown on the diagram for your application. (See wiring)
3. Remove thermostat cover by grasping top and bottom of cover and pull straight out. Dress wiring into switch box and secure thermostat to outlet box with mounting screws.

NOTE: DO NOT PUSH OR DAMAGE THE KNOB SENSING ELEMENT DURING INSTALLATION.

4. Install thermostat cover and turn knob to desired setting.

Maximum Limit Dial Setting

By installing one Stop, the maximum limit temperature may be set. (Example: Fig. A, Max. Limit Setting 78°F or 26°C)

1. From Figure "A" select the hole at the outer edge of the knob which corresponds to the maximum dial setting you desire.
2. Rotate knob counter-clockwise to lowest setting. Remove thermostat cover by grasping top and bottom and pull straight out.
3. Position stop under knob so the hole in the stop and selected hole in thermostat base are aligned. Insert pin into aligned holes, but do not push pin completely down. (Fig. "D")
4. Rotate knob clockwise to its newly selected maximum setting. With the thermostat cover in place, this should now be the maximum temperature setting you selected in step #1. If setting is incorrect, the stop is still removable and may be moved to another hole.
5. With stop installed in the correct hole, the pin can now be seated down on the stop by pushing with the blade of a screwdriver or gently tapping with a light object. **Use care not to hit the knob.** The stop is now installed and cannot be removed.

Minimum Limit Dial Setting

By installing one Stop, the minimum temperature may be set. (Example: Fig. B, Min. Limit Setting 69°F or 21°C)

1. From Figure "B" select the hole at the outer edge of the knob which corresponds to the minimum dial setting you desire.
2. Rotate knob clockwise to highest setting. Remove thermostat cover by grasping top and bottom and pull straight out.
3. Position stop under knob so the hole in the stop and selected hole in thermostat base are aligned. Insert pin into aligned holes, but do not push pin completely down. (Fig. "D")
4. Rotate knob counter-clockwise to its newly selected minimum setting. With the thermostat cover in place, this should now be the minimum temperature setting you selected in step #1. If setting is incorrect, the stop is still removable and may be moved to another hole.
5. With stop installed in the correct hole, the pin can now be seated down on the stop by pushing with the blade of a screwdriver or gently tapping with a light object. **Use care not to hit the knob.**

Locked Dial Setting

By installing two Stops, the Knob may be locked at a selected temperature (Fig. C)

1. Select the temperature setting at which the knob is to be locked and locate the corresponding hole in Fig. "A" (minimum 66°F or 19°C, maximum 81°F or 27°C). Install the first stop as described in maximum limit dial setting section.
2. Rotate the knob clockwise until it hits the first stop. Install the second stop in the same manner in the second hole down from first stop. (Example: Fig. C. Knob setting is locked at 72°F or 22°C and cannot be changed.)

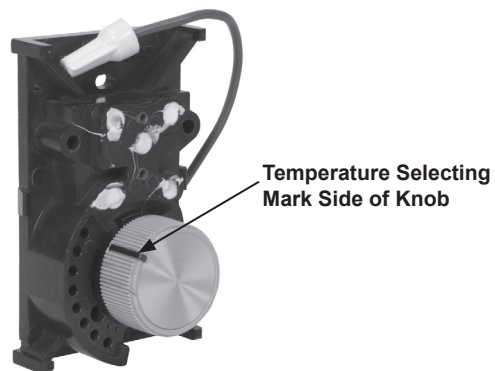
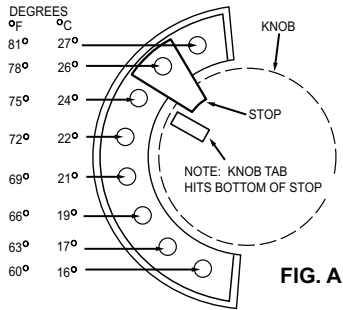
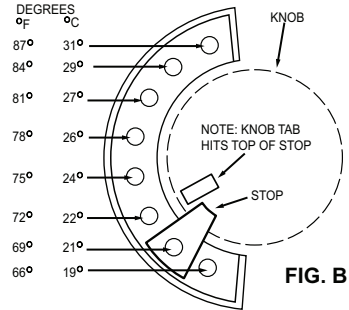

FIG. D

MAX. DIAL SETTING STOP



MIN. DIAL SETTING STOP



LOCKED DIAL SETTING

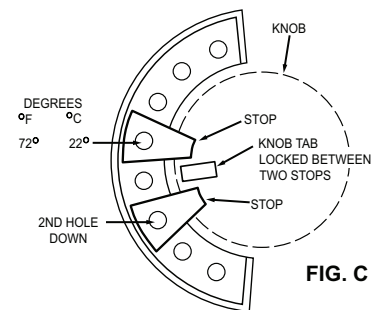

LOCKED DIAL SETTING OR LIMITED SETTING STOPS

The enclosed stops may be used to provide "LOCKED DIAL SETTING" or "LIMITED SETTING". Instructions for installing the stops to perform either of these functions are given below.

NOTE: Once stops are installed, they cannot be removed.

PACKAGE CONTAINS:

2 – stops

2 – pins

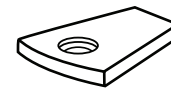

STOP



PIN

CAUTION

To prevent electrical shock and/or equipment damage, disconnect electric power to system, at main fuse or circuit breaker box, until installation is complete.

NOTE: All wiring should be installed according to local and national electrical codes and ordinances.

INTERNAL SCHEMATIC OF 1A10

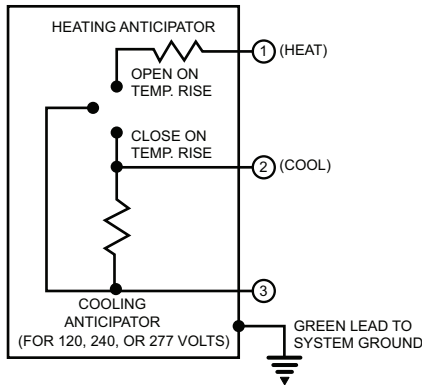

TYPICAL HOOK-UP FOR HEATING ONLY SYSTEM

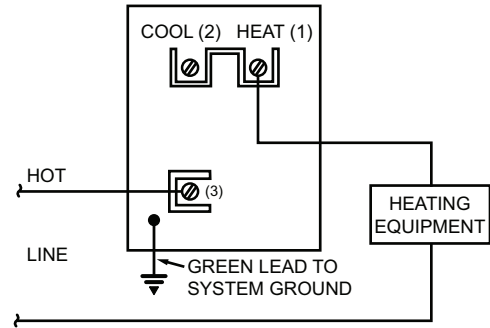

TYPICAL HOOK-UP FOR COOLING ONLY SYSTEM

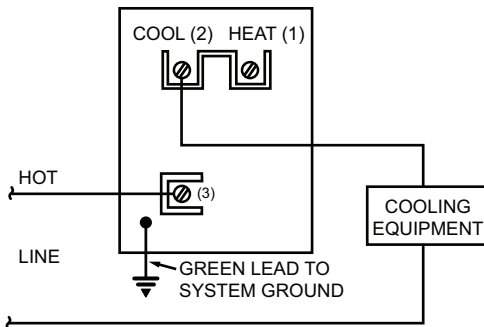

HEATING-COOLING SYSTEM USING A MANUAL CHANGEOVER SWITCH

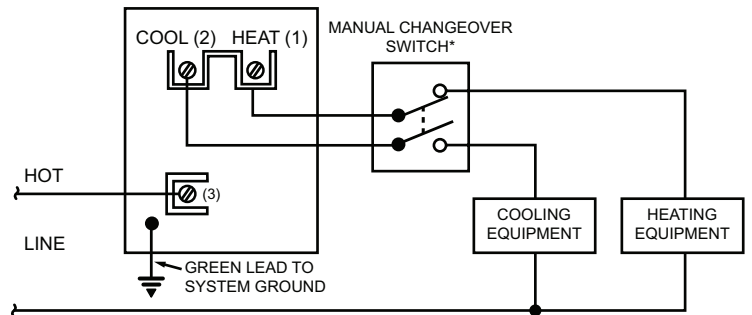

* POSITIVE OFF OR SYSTEM SELECTION CAN BE OBTAINED BY USING A SWITCHING SUB-BASE

FAN COIL SYSTEM

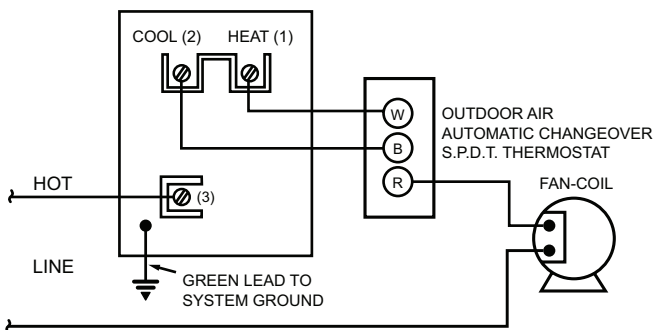

HEATING-COOLING FAN-COIL SYSTEM USING TWO OR MORE THERMOSTATS

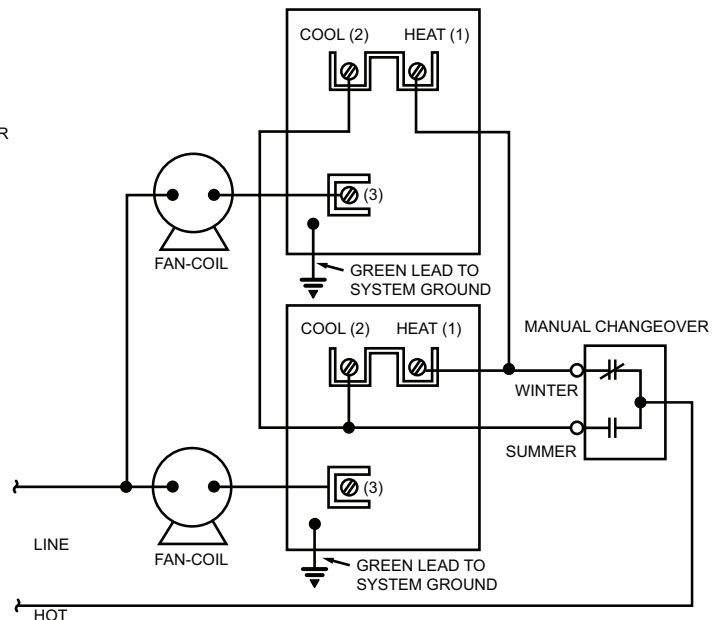

White-Rodgers is a business of Emerson Electric Co.

The Emerson logo is a trademark and service mark of Emerson Electric Co.

White-Rodgers™

white-rodgers.com
emersonclimate.com

EMERSON™
Climate Technologies